

PROFESSIONAL RANGE

**Grease
Guardian®**

GGX75-STAND

**GREASE GUARDIAN GGX75
SUPPORT STAND**



Grease Guardian GGX75
Accessory
Suitable for
GGX75-IS
GGX75-AST
Elevated Support Stand



STAINLESS STEEL CONSTRUCTION
DURABLE - RELIABLE - BUILT TO LAST

Grease Management Solutions For Your Kitchen

MODEL # GGX75-STAND

Centralized Equipment

TECHNICAL DATA

WEIGHT	65 pounds
LENGTH	45.3in
WIDTH	18.35in
HEIGHT	24in
MATERIAL	Stainless Steel
SUPPORT	Angle
ASSEMBLY	Bolts + Threaded Nuts
FASTENERS	48 Bolts
WARRANTY	3 Years

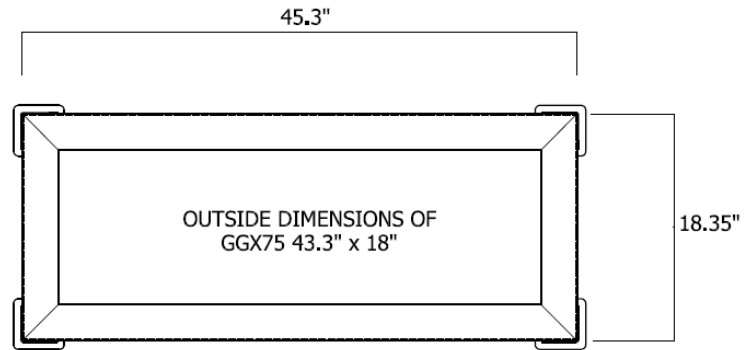

TOP VIEW

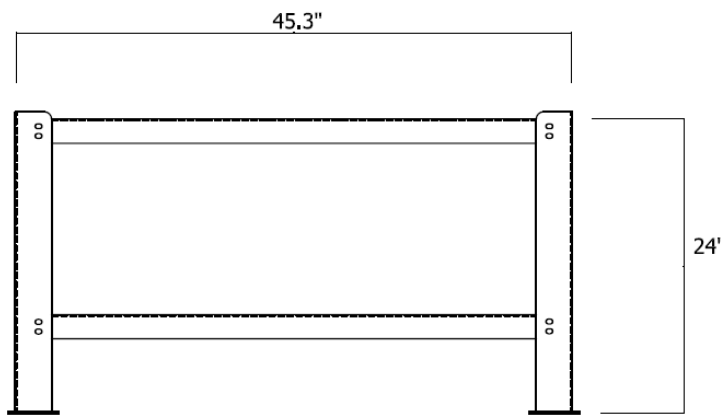

FRONT VIEW

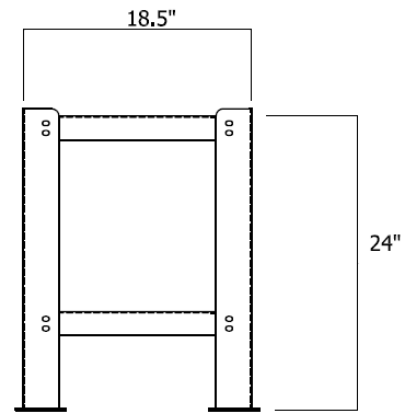

END VIEW

Specification

□ Grease Guardian Model GGX75-STAND, 16 gauge fully welded 304 stainless steel support Stand. The Grease Guardian GGX75-STAND is designed to elevate the Grease Guardian models GGX75-IS and GGX75-AST, giving the application the necessary height to be used in conjunction with a 30 gallon or 55 gallon grease collection drum. Each GGX75-STAND is supplied with 48 bolts for assembly, Threaded nuts are welded in place. 3 year warranty is standard.

The stand is packaged flat for convenience. All stands come with the necessary hardware for quick assembly.

MODEL # GGX75-STAND